

Power operated two jaw wedge hook chucks

Two jaw chucks are predominantly used when machining irregular shaped components and are therefore mainly used with workpiece specific jaws. When machining fittings or similar parts, it is often necessary to grip over projections. Also ball shaped parts must be enveloped by the jaws. This necessitates a relatively long jaw stroke.

The FORKARDT 2BLN chucks are designed to match these production requirements perfectly. The jaw slides and all moving internal parts are made

from high alloy steel and hardened to ensure a long service life. As with three jaw chucks, the top jaws of the 2BLN chuck are located on serrations and can easily be adjusted or changed. The base jaws of the chuck have lubrication facilities and the chuck body is recessed to reduce weight.

The top jaws are generally specially made to match the workpiece. Two-jaw chucks without rapid traverse for internal and external chucking are available on request.



Technical data

		2BLN 125	2BLN 160	2BLN 200	2BLN 250	2BLN 315	2BLN 400
Max. actuating force	(daN)	1300	1600	4200	4500	4500	5700
Gripping Force at max. actuating force	(daN)	2000	2600	6200	6600	6600	9000
Speed	(1/min)	3500	3000	3000	2500	2200	2000
Weight	(kg)	5	9	17	25	36.5	60
Moment of inertia GD ²	(kpm ²)	0.04	0.16	0.35	0.7	1.6	4.5
Soft top jaws	Type	2BLEWB 125	2BLEWB 160	2BLEWB 200	2BLEWB 250	2BLEWB 315	2BLEWB 400

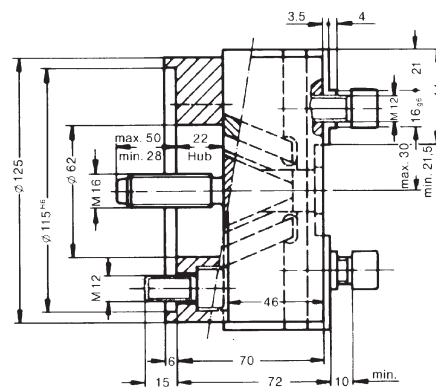
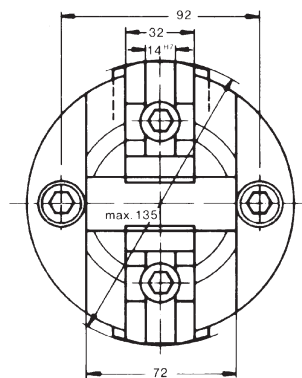

2BLN 125

Ident-Number: D154890000

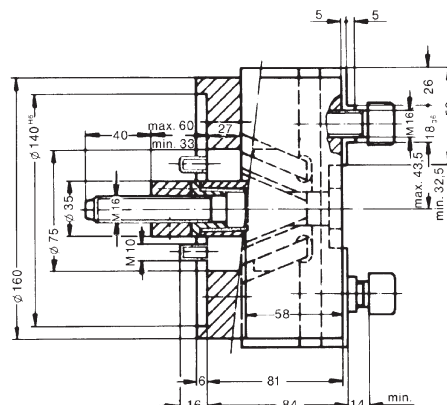
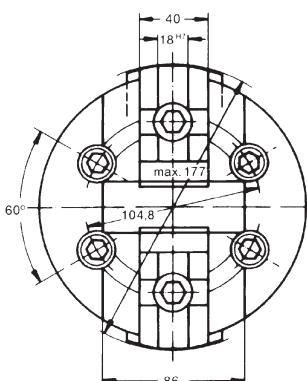

2BLN 160

Ident-Number: D154891000

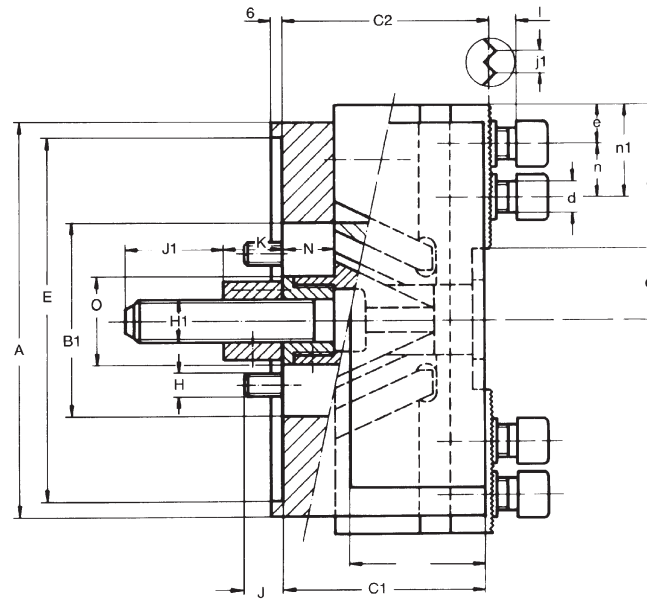
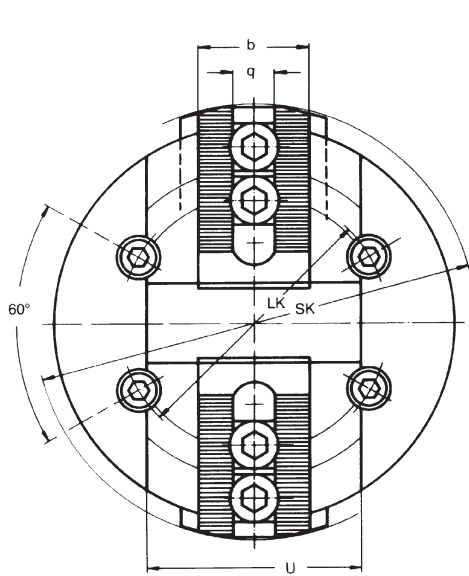

2BLN 200...400

LK = Pitch circle
SK = Outer most

Dimensions

Type 2BLN	200	250	315	400
Ident-No.	D154892000	D154893000	D154894000	D154895000
A	200	250	315	400
B1 H6	98	98	98	120
C1	100	102	102	108
C2 -0.1	103.7	105.7	105.7	111.7
E H6	185	220	220	300
H	M12	M16	M16	M24
H1	M22	M22	M22	M24
J	20	25	25	35
J1	50	50	50	50
K max	60	60	60	55
K min	30	29	29	25
N	30	31	31	30
O	44	44	44	52
U	108	115	120	135
Pitch circle ± 0.2	133.4	171.4	171.4	235
Outer diameter max	220	270	334	420

Type 2BLN	200	250	315	400
a	73	98	130	168
b	55	55	55	60
c max	36	36.4	36.4	40
c min	22	22	22	26
d	M16	M20	M20	M20
e min	12	14	14	14
j1 90°	1/16"	1/16"	1/16"	1/16"
l min	12	16	16	16
n	25	31	31	31
n1 max	60	84	116	154
q H7 g6	21	25.5	25.5	25.5
Stroke per jaw	14.0	14.4	14.4	14.0

Pitch circle fitting to DIN 55026 ISO R 701

L O C A T I O N S W O R L D W I -

FORKARDT GMBH
Lachenauweg 12
72766 Reutlingen-Mittelstadt
Phone: (+49) 211 25 06-0
Fax: (+49) 211 25 06-221
E-Mail: info@forkardt.com

FORKARDT USA
2155 Traversefield Drive
Traverse City, MI 49686, USA
Phone: (+1) 800 544-3823
(+1) 231 995-8300
Fax: (+1) 231 995-8361
E-Mail: sales@forkardt.us
Website: www.forkardt.us

FORKARDT FRANCE S.A.R.L.
28 Avenue de Bobigny
F-93135 Noisy le Sec Cédex
Phone: (+33) 1 4183 1240
Fax: (+33) 1 4840 4759
E-Mail: forkartd.france@forkardt.com

FORKARDT CHINA
Room B,1F, Bldg 45#,
209 Taigu Rd.
Shanghai Waigaoqiao F.T.Z.
200131 P.R.C
Phone: (+86) 021 5868 3677
E-mail: info@forkardt.cn.com
Website: www.forkardt.us

FORKARDT INDIA LLP
Plot No. 39 D.No.5-5-35
Ayyanna Ind. Park
IE Prasanthnagar, Kukatpally
Hyderabad - 500 072
India
Tel: (+91) 40 400 20571
Fax: (+91) 40 400 20576
E-Mail: info@forkardtindia.com

www.forkardt.com

www.forkardt.us