

Stoßdämpfer · Shock Absorbers

Amortisseurs · Deceleratori · Amortiguadores



GB

Enlarged Piston
ProSurf
Extended Life Time

High energy absorption
Long-life surface protection (p. 6)
Nitrated guidance system
Piston rod: hardened stainless steel
Special seals + oils

Integrated End Stop
Flats
Temperature

-20°C - +80°C
Optional from WS-M 10x6:
-50°C - +60°C / 0°C - +120°C

Special models

Stainless steel (Page 62,63)
Pressure chambers up to 7 bar
USDA-H1-compliant for food industry

I

Pistone allargato
ProSurf
Lunga durata

Assorbimento di alta energia
Durevole protezione delle superfici (p. 6)
Pistone: Sistema di guida nitrato
Stelo del pistone: acciaio temprato inossidabile
Guarnizioni + olio speciale

Battuta integrata
Superfici piane
Temperatura

-20°C - +80°C
Opzionale da WS-M 10x6:
-50°C - +60°C / 0°C - +120°C

Versione speciale

Acciaio inox (Pagina 62,63)
Camera di pressione fino a 7 bar
Industria alimentare secondo USDA-H1

D

Vergrößerter Kolben
ProSurf
Lange Lebensdauer

Hohe Energieaufnahme
Langlebiger Oberflächenschutz (S. 6)
Gehärtete Kolbenführung
Kolbenstange: gehärteter rostfreier Stahl
Spezialdichtungen + Öle

Integrierter Festanschlag
Schlüssel­flächen
Temperaturbereich

-20°C - +80°C
Optional ab WS-M 10x6:
-50°C - +60°C / 0°C - +120°C

Sonderausführungen

Edelstahl (Seite 62,63)
Druckraum bis 7 bar
Lebensmittelindustrie nach USDA-H1

F

Piston massif
ProSurf
Longévité

Energie d'absorption élevée
Protection de surface durable (p. 6)
Système de guidage nitruré
Tige de piston: acier trempé inoxydable
Joints et huiles spécifiques

Butée de fin de course intégrée
Plats usiné

Températures
-20°C - +80°C
Option de WS-M 10x6:
-50°C - +60°C / 0°C - +120°C

Version spéciale

INOX (page 62,63)
Chambres pressurisées jusqu'à 7 bars
Industrie alimentaire selon USDA-H1

E

Émbolo mayor
ProSurf
Larga vida útil

Alta absorción de energía
Protección duradera de superficies (p. 6)
Émbolo: cojinete de guía templado
Vástago del émbolo: en acero inoxidable templado
Juntas + aceites especiales

Tope fijo integrado
Superficies planas
Temperaturas

-20°C - +80°C
Opcional de WS-M 10x6:
-50°C - +60°C / 0°C - +120°C

Edición especial

Acero inoxidable (Página 62,63)
Cámara de presión de hasta 7 bar
Industria alimenticia conforme a USDA-H1

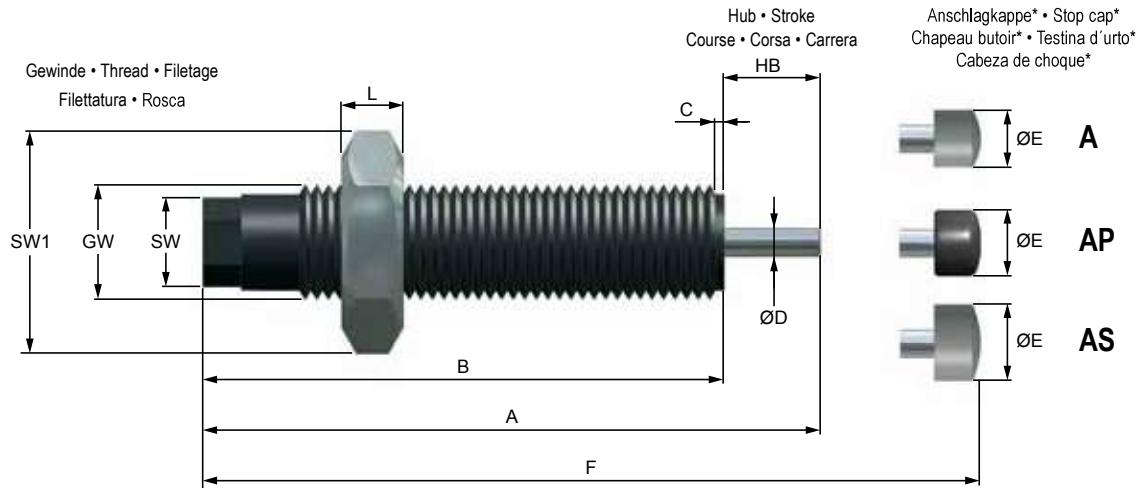

ABMESSUNGEN • DIMENSIONS • DIMENSIONI • DIMENSIONES

	GW	A	B	C	Ø D	ØE (A)	ØE (AP)	ØE (AS)	F (A)	F (AP)	F (AS)	L	SW	SW1
	mm	mm	mm	mm	mm	mm	mm	mm	mm	mm	mm	mm	mm	mm
WS-M 4 x 4	M 4 x 0,35	29,0	25,0	2,0	1,5	3,0	4,3	-	33,0	-	-	3,0	3,0	7,0
WS-M 5 x 4	M 5 x 0,5	29,0	25,0	2,0	1,5	3,0	4,3	-	33,0	33,0	-	3,0	4,0	8,0
WS-M 6 x 5	M 6 x 0,5	32,0	27,0	2,0	2,0	5,0	5,3	-	37,0	37,0	-	3,0	4,0	8,0
WS-M 8 x 5	M 8 x 1	35,0	30,0	2,5	2,3	6,0	6,5	-	41,0	41,5	-	3,0	5,5	11,0
WS-M 10 x 6	M 10 x 1	37,0	31,0	2,5	3,0	6,0	8,5	8,5	43,5	43,5	43,5	3,0	7,0	13,0
WS-M 10 x 8	M 10 x 1	48,0	40,0	2,5	3,0	6,0	8,5	8,5	54,5	54,5	54,5	3,0	7,0	13,0
WS-M 12 x 10	M 12 x 1	61,0	51,0	2,5	4,0	10,0	10,0	10,0	69,0	69,5	69,0	4,0	9,0	14,0

LEISTUNGEN • PERFORMANCE • CARATTERISTICHE TECNICHE • CARACTERÍSTICAS TÉCNICAS

	Hub Stroke Course Corsa Carrera	Energieaufnahme - Energy absorption Energie d'absorption - Assorbimento d'energia Absorción de energía			Effektive Masse - Effective mass Masse effective Massa efectiva - Masa efectiva			Aufprallgeschwindigkeit Impact Speed Vitesse d'impact Velocità d'impatto Velocidad de impacto	Rückholfederkraft Return spring force Force du ressort Forza di ritorno Fuerza del muelle recuperador
		Constant load*	Emergency**	Nm/h (max.)	-1 (soft)	-2 (medium)	-3 (hard)		
	mm	Nm/HB (max.)	Nm/HB (max.)	Nm/h (max.)	min. - max.kg	min. - max.kg	min. - max.kg	m/s	N
WS-M 4 x 4	4	0,4	0,7	1500	0,1 - 1	0,9 - 3,2	-	0,2 - 1,5	2 - 7
WS-M 5 x 4	4	0,6	1,0	1800	0,1 - 1,2	1,0 - 5,0	-	0,2 - 2,0	2 - 7
WS-M 6 x 5	5	1,0	1,5	3000	0,05 - 1	0,8 - 2,8	1,5 - 4	0,2 - 2,5	2 - 5
WS-M 8 x 5	5	1,5	2,0	4000	0,25 - 3	0,7 - 6	3 - 9	0,2 - 2,5	2 - 5
WS-M 10 x 6	6	2,2	3,0	12000	0,7 - 3	3 - 10	8 - 18	0,2 - 2,5	3 - 6
WS-M 10 x 8	8	3,0	4,0	24000	0,9 - 9	2 - 12	9 - 23	0,2 - 3	3 - 6
WS-M 12 x 10	10	9,0	12,0	27450	1 - 15	10 - 42	25 - 61	0,2 - 3	4 - 10

*Dauerbelastung - Constant load - Charge permanente - Carico permanente - Carga continua / **Notfall - Emergency - Urgence - Emergenza - Emergencia

Gewicht	M4x4 / M5x4 / M6x5:	3 g
Weight	M8x5:	7 g
Poids	M10x6:	11 g
Peso	M10x8:	14 g
Peso	M12x10:	30g

Drehmoment: max. Kraft bei Benutzung der Schlüssel­flächen
Torque: max. force by using the flats
Couple de serrage: max disponible en utilisant les plats
Coppia di serraggio max. utilizzando le superfici piane
Par: fuerza máxima utilizando la superficies planas

M 4 x 4:	0,8 Nm
M 5 x 4:	1,0 Nm
M 6 x 5:	1,2 Nm
M 8 x 5:	2 Nm
M 10 x X:	4 Nm
M 12 x 10:	8 Nm

Lieferumfang	1 Kontermutter
Included	1 Lock nut
Inclus	1 Contre-écrou
Incluso	1 Controdado
Incluido	1 Contratuercia

Zubehör	Seite 21
Accessories	Pages 21
Accessoires	Page 21
Accessori	Pagina 21
Accesorios	Página 21